

Torque arm, 1-arm (mounting kit 047)

Bolt circle $\varnothing 63...94$ mm, mounting M4

Article number: 11113210

Overview

- Universal torque arm for mounting hole circle 63...94 mm
- Flexible 30° alignment



Technical data

Technical data - mechanical design

Weight approx. 6 g

Description

Torque support onto encoder by help of the attached screws. Push encoder onto the drive shaft and mount torque support onto the client side. Fastening clamping ring with clamping ring screw.

Scope of delivery

Torque support, three screws M3 x 6 (DIN 7985 - TX10)

Suitable for

EIL580-B, EIL580-T, EIL580P-B, EIL580P-T

Dimensions

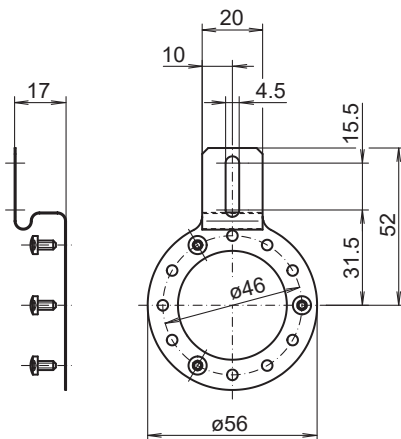

Assembly drawing

