

Torque arm, 1-arm (mounting kit 021)

Bolt circle $\varnothing 65.5 \dots 281$ mm, mounting M4, can be cut to length

Article number: 11073119

Overview

- Universal mounting option by several pitch diameters.

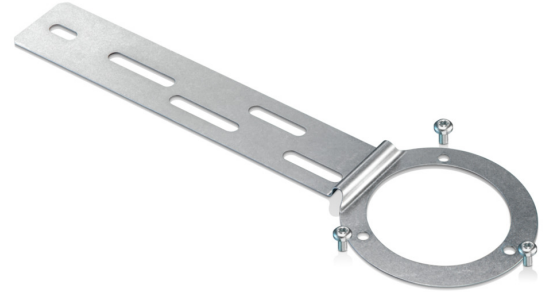

Technical data

Technical data - mechanical design

Weight approx. 14 g

Description

Torque support onto encoder by help of the attached screws. Push encoder onto the drive shaft and mount torque support onto the client side. Fastening clamping ring with clamping ring screw.

Scope of delivery

Torque support, three screws M3 x 6 (DIN 7985 - TX10)

Suitable for

ATD2AH00, EIL580-B, EIL580-T, EIL580P-B, EIL580P-T, ITD21H00, ITD21H00 HT, ITD22H00, ITD22H00 SIL

Dimensions

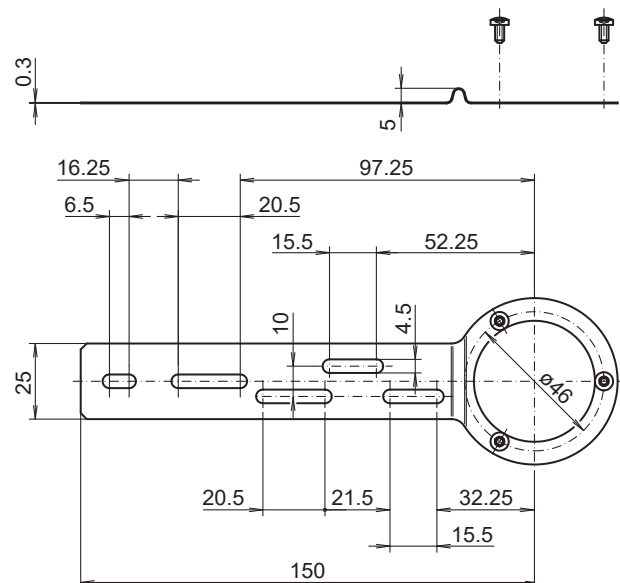

Assembly drawing

